

Australian Patent No 2002313921

INFFUSER™ IDT

Technical Data

1200 x 46mm 1 Slot Light Air Boot
1-Way Blow with External Entrainment

Release V.1 July 2007

Infuser

Table 1: Zone Sensible Capacity [W]

Floor Area [m ²]	Zone Load [W/m ²]																		
	15	30	35	40	45	50	60	70	80	90	100	110	120	130	140	150	160	180	200
8	120	240	280	320	360	400	480	560	640	720	800	880	960	1040	1120	1200	1280	1440	1600
10	150	300	350	400	450	500	600	700	800	900	1000	1100	1200	1300	1400	1500	1600	1800	2000
12	180	360	420	480	540	600	720	840	960	1080	1200	1320	1440	1560	1680	1800	1920	2160	2400
14	210	420	490	560	630	700	840	980	1120	1260	1400	1540	1680	1820	1960	2100	2240	2520	2800
16	240	480	560	640	720	800	960	1120	1280	1440	1600	1760	1920	2080	2240	2400	2560	2880	3200
18	270	540	630	720	810	900	1080	1260	1440	1620	1800	1980	2160	2340	2520	2700	2880	3240	3600
20	300	600	700	800	900	1000	1200	1400	1600	1800	2000	2200	2400	2600	2800	3000	3200	3600	4000
22	330	660	770	880	990	1100	1320	1540	1760	1980	2200	2420	2640	2860	3080	3300	3520	3960	4400
24	360	720	840	960	1080	1200	1440	1680	1920	2160	2400	2640	2880	3120	3360	3600	3840	4320	4800
26	390	780	910	1040	1170	1300	1560	1820	2080	2340	2600	2860	3120	3380	3640	3900	4160	4680	5200
28	420	840	980	1120	1260	1400	1680	1960	2240	2520	2800	3080	3360	3640	3920	4200	4480	5040	5600
30	450	900	1050	1200	1350	1500	1800	2100	2400	2700	3000	3300	3600	3900	4200	4500	4800	5400	6000

Table 2: Primary Air Flow [L/s]

Sensible Capacity [W]	Temperature Differential (room air - primary air)										
	7	8	9	10	11	12	13	14	15	16	17
1500	177	155	137	124	112	103	95	88	82	77	73
1400	165	144	128	115	105	96	89	82	77	72	68
1300	153	134	119	107	97	89	82	77	71	67	63
1200	141	124	110	99	90	82	76	71	66	62	58
1100	130	113	101	91	82	76	70	65	60	57	53
1000	118	103	92	82	75	69	63	59	55	52	48
950	112	98	87	78	71	65	60	56	52	49	46
900	106	93	82	74	67	62	57	53	49	46	44
850	100	88	78	70	64	58	54	50	47	44	41
800	94	82	73	66	60	55	51	47	44	41	39
750	88	77	69	62	56	52	48	44	41	39	36
700	82	72	64	58	52	48	44	41	38	36	34
650	77	67	60	54	49	45	41	38	36	33	32
600	71	62	55	49	45	41	38	35	33	31	29
550	65	57	50	45	41	38	35	32	30	28	27
500	59	52	46	41	37	34	32	29	27	26	24
450	53	46	41	37	34	31	29	26	25	23	22
400	47	41	37	33	30	27	25	24	22	21	19
350	41	36	32	29	26	24	22	21	19	18	17
300	35	31	27	25	22	21	19	18	16	15	15
250	29	26	23	21	19	17	16	15	14	13	12
200	24	21	18	16	15	14	13	12	11	10	10

Figures in blue indicated pressures greater than 65Pa for 88 nozzles

Quick Selection Procedure

1. If the actual zone sensible load is unknown then use table 1 for a nominated zone load and floor area.
2. When the sensible capacity is known use table 2 to achieve a primary air flow for the designed temperature difference.
3. Table 3 can be used to determine the required total supply air flow for the required air circulation rate.
4. Use table 4 to select the nozzle configuration that best satisfies your criteria.
5. Table 5 & 6 can be used to check the mixed supply air temperature to the zone.
6. Check heating requirements using tables 2, 4 and 6.

Table 3: Total Supply Air Flow [L/s]

Floor Area [m ²]	Air Circulation Rate [L/s/m ²]															
	1.5	2	2.5	3	3.5	4.0	4.5	5	6	7	8	9	10	12.5	15	20
8	12	16	20	24	28	32	36	40	48	56	64	72	80	100	120	160
10	15	20	25	30	35	40	45	50	60	70	80	90	100	125	150	200
12	18	24	30	36	42	48	54	60	72	84	96	108	120	150	180	240
14	21	28	35	42	49	56	63	70	84	98	112	126	140	175	210	280
16	24	32	40	48	56	64	72	80	96	112	128	144	160	200	240	320
18	27	36	45	54	63	72	81	90	108	126	144	162	180	225	270	360
20	30	40	50	60	70	80	90	100	120	140	160	180	200	250	300	400
22	33	44	55	66	77	88	99	110	132	154	176	198	220	275	330	440
24	36	48	60	72	84	96	108	120	144	168	192	216	240	300	360	480
26	39	52	65	78	91	104	117	130	156	182	208	234	260	325	390	520
28	42	56	70	84	98	112	126	140	168	196	224	252	280	350	420	560
30	45	60	75	90	105	120	135	150	180	210	240	270	300	375	450	600

Table 4: IDT Performance Data

IDT (Single Light Air Boot)						
Spigot Size	Nozzle Configuration					
	44 150 mm		58 150 mm		88 150 mm	
	Primary Air [L/s]	Supply Air [L/s]	Primary Air [L/s]	Supply Air [L/s]	Primary Air [L/s]	Supply Air [L/s]
Pressure [Pa]						
5	11	21	14	24	21	26
10	15	29	20	32	29	35
15	18	35	24	38	35	42
20	21	40	27	43	41	47
25	23	44	30	47	45	52
30	25	48	33	50	50	56
35	27	51	35	54	53	60
40	29	54	37	57	57	64
45	30	57	39	60	60	67
50	32	60	41	62	63	71
55	33	63	43	65	66	74
60	35	66	45	67	69	77
65	36	68	47	70	72	80
70	37	70	48	72	75	82
75	38	73	50	74	77	85
80	40	75	51	76	80	87
85	41	77	53	78	82	90
90	42	79	54	80	84	92
95	43	81	55	82	86	94
100	44	83	57	84	89	97
105	45	85	58	85	91	99

Primary air & total air performance for nominal 1192mm length unit

Table 5: IDT Supply Air Temp (Cooling)

Nozzle Config.	Primary Air Temp [°C]	Room Air Temperature [°C]			
		22	23	24	25
44	8	14.6	15.1	15.6	16.1
	9	15.2	15.6	16.1	16.6
	10	15.7	16.2	16.6	17.1
	11	16.2	16.7	17.2	17.6
	12	16.7	17.2	17.7	18.2
	13	17.3	17.7	18.2	18.7
58	8	12.8	13.1	13.5	13.8
	9	13.4	13.8	14.1	14.5
	10	14.1	14.4	14.8	15.1
	11	14.8	15.1	15.4	15.8
	12	15.4	15.8	16.1	16.4
	13	16.1	16.4	16.8	17.1
88	8	9.5	9.6	9.7	9.8
	9	10.4	10.5	10.6	10.7
	10	11.3	11.4	11.5	11.6
	11	12.2	12.3	12.4	12.5
	12	13.1	13.2	13.3	13.4
	13	14.0	14.1	14.2	14.3

Table 6: IDT Supply Air Temp (Heating)

Nozzle Config.	Primary Air Temp [°C]	Room Air Temperature [°C]			
		20	21	22	23
44	28	24.2	24.7	25.2	25.6
	30	25.3	25.7	26.2	26.7
	32	26.3	26.8	27.3	27.7
	34	27.4	27.8	28.3	28.8
	36	28.4	28.9	29.4	29.8
	38	29.5	29.9	30.4	30.9
58	28	25.3	25.6	25.9	26.3
	30	26.6	26.9	27.3	27.6
	32	27.9	28.2	28.6	28.9
	34	29.2	29.6	29.9	30.2
	36	30.5	30.9	31.2	31.6
	38	31.8	32.2	32.5	32.9
88	28	27.1	27.3	27.4	27.5
	30	28.9	29.0	29.1	29.3
	32	30.7	30.8	30.9	31.0
	34	32.5	32.6	32.7	32.8
	36	34.3	34.4	34.5	34.6
	38	36.1	36.2	36.3	36.4

Table 7: IDT Acoustic Data

Nozzle Configuration	Primary Air Pressure [Pa]	Sound Power Level [dB]								dB[A]	NC	NR
		Octave Band Frequency [Hz]										
		63	125	250	500	1000	2000	4000	8000			
44	20	11	21	18	14	11	13	15	14	25	17	18
	40	15	21	24	22	18	14	12	12	28	19	22
	60	14	24	28	28	24	21	13	12	33	25	27
	80	17	27	32	31	28	26	16	12	37	29	31
	100	19	30	34	34	31	30	20	12	39	32	33
58	20	6	15	16	15	11	10	13	12	22	10	14
	40	11	21	25	23	19	15	13	12	29	20	23
	60	15	24	29	29	25	22	13	12	34	26	28
	80	17	27	33	33	30	28	16	12	38	32	32
	100	19	30	36	36	34	32	21	12	41	35	36
88	20	9	17	18	16	10	8	12	12	23	12	15
	40	11	21	25	25	20	16	12	12	30	22	24
	60	14	25	29	30	26	24	14	12	35	28	29
	80	17	29	33	34	31	29	18	12	39	33	34
	100	19	31	36	37	35	33	22	13	42	36	37

NOTE: The above tabulated noise data are based on tests taken in The University of Adelaide's Reverberation Chamber
Please contact DADANCO for further information on the parameters under which the noise data are measured.

Air Diffuser Performance

The INFFUSER™ IDTs is designed so the airflow 'hugs' the ceiling ('Coanda effect') and so discharges the supply air into the space gently and uniformly. The entrainment of secondary air and Coanda effect is maintained even when the primary air volume is reduced to below 50% of the design peak load value.

INFFUSER™ IDTs diffuser performance will be dependent on the geometry, length and width of the supply air slots in the lighting fixture.

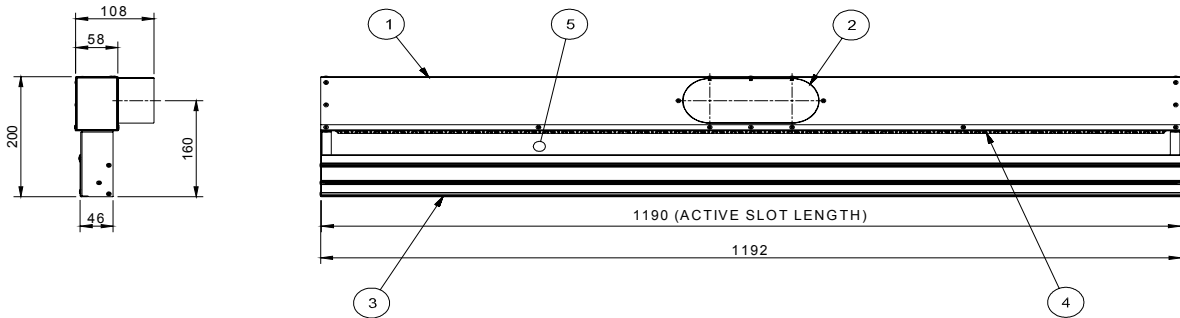

- 1. Insulated primary air plenum
- 2. Oval inlet spigot, (150mm dia equivalent shown)
- 3. Diffuser (1-slot)
- 4. Primary air nozzles
- 5. Secondary air opening

NOTES:
 IDT Inffusers must be coordinated with lighting fixtures for final dimensions
 Natural finish with matt black painted supply air slot & nozzle plate
 Internally insulated primary air plenum

Approximate Unit Weight 4kg

For more information on INFFUSERS™, or other Dadanco solutions delivery, products, contact:



DISCLAIMER: While every effort is made to ensure the details contained herein are kept up to date in the interest of ongoing product development, DADANCO reserves the right to alter the same without notice

info@dadanco.com.au
 www.dadanco.com.au