

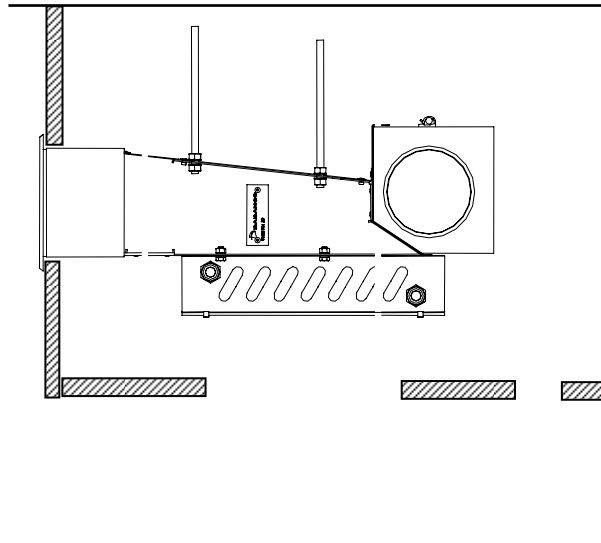

PRODUCT INFORMATION
INSTALLATION & MAINTENANCE
INSTRUCTIONS



**HM30.03 - Horizontal
Induction Terminal Unit
without Drain Tray**



DADANCO

Breathing Life into Your Building

DESCRIPTION

STARLINE HM30 horizontal mounted induction terminal units are designed for horizontal (Bulkhead) installation with horizontal air discharge, and are manufactured to suit three coil heights and nine unit lengths (Refer Table A).

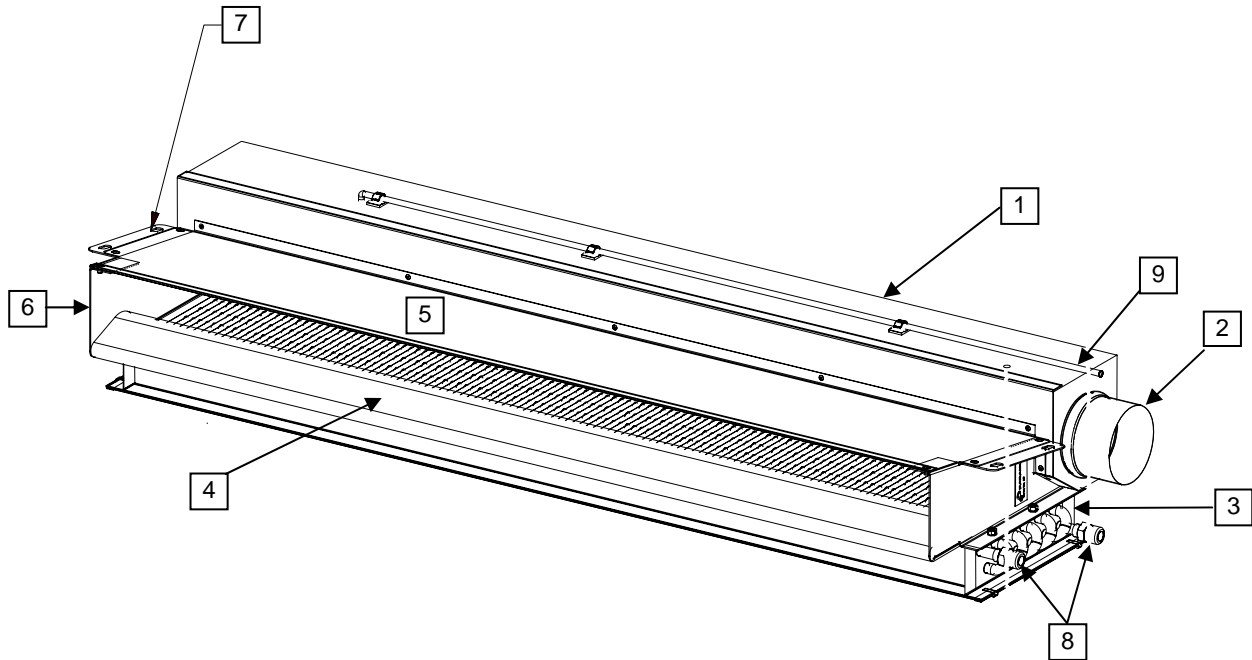

- | | | |
|------------------------------|--------------------------------|-------------------------|
| 1. Primary air plenum | 4. Mixing Chamber & Air Outlet | 7. Mounting brackets |
| 2. Primary air spigot Ø100mm | 5. Back Plate | 8. ½" BSP Male Fittings |
| 3. Heat exchanger coil | 6. End Plates | 9. Commissioning Tube |

UNIT CONSTRUCTION

As shown in the above figure, each induction unit is comprised of:

- Primary air plenum (1), which accommodates an array of primary air nozzles, a Ø100mm primary air spigot (2) and a Ø4mm air pressure commissioning tube (9).
- Air entrainment / mixing chamber (4), comprised of a fixed back plate (5), two end plates (6) and a profiled sidewall section at the air outlet opening.
- Heat exchanger coil (3), of aluminium finned 1/2" copper tube with 1/2" BSP male water inlet / outlet (9) fittings and protected by a fine mesh lint screen. The heat exchanger coil (3) is attached to the air entrainment / mixing chamber by M6 bolts, secured into the end plates (6).

STARLINE HM30 units are suitable for a wide variety of air and water handing configurations that must be designated prior to manufacture.

Water connection handings can be reversed in the field by removing, reversing and replacing the secondary heat exchanger coil to the preferred side of the unit.

Primary air spigot handing must be designated left or right prior to manufacture as it cannot be reversed in the field.

PHYSICAL DATA

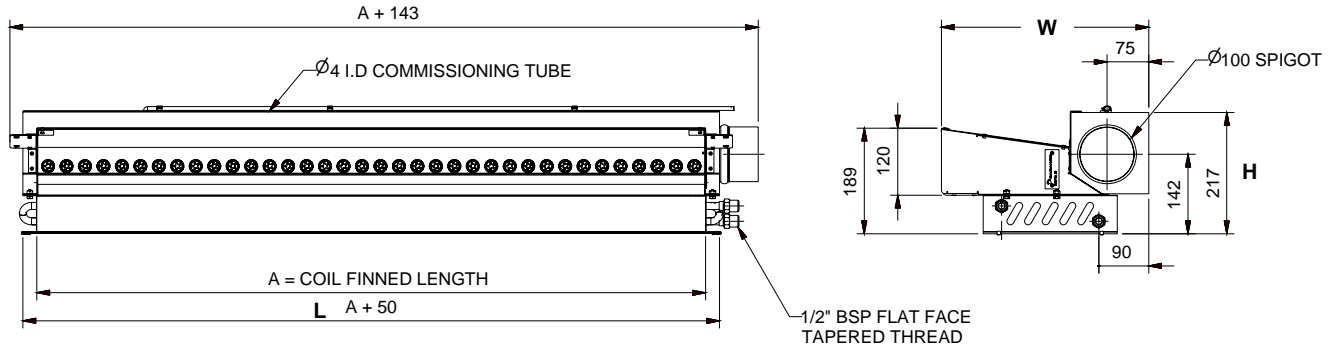

HM30 PHYSICAL DATA (Table A)

Unit Model	Coil Finned Length A (mm)	Air Plenum Length L (mm)	Overall Length (mm)	H = Unit Height (mm) Without Drip Tray			W = Unit Width (mm)		
				6 Tube	8 Tube	10 Tube	6 Tube	8 Row	10 Tube
HM30-0700.---	700	750	843						
HM30-0800.---	800	850	943						
HM30-0900.---	900	950	1043						
HM30-1000.---	1000	1050	1143						
HM30-1050.---	1050	1100	1193	217	217	217	372	436	499
HM30-1100.---	1100	1150	1243						
HM30-1200.---	1200	1250	1343						
HM30-1300.---	1300	1350	1443						
HM30-1400.---	1400	1450	1543						
HM30-1500.---	1500	1550	1643						

HM30 PRIMARY AIR FLOW OPERATING RANGE (Table B)

HM30 Induction Terminal Unit	Primary Air Flow Range (L/sec) @ Primary Air Static Pressure (Pa)				
	100 Pa	150 Pa	200 Pa	250 Pa	300 Pa
HM30-0700.---	6.4 – 18.5	7.9 – 22.8	9.2 – 26.5	10.4 – 29.9	11.4 – 32.7
HM30-0800.---	7.3 – 21.3	9.1 – 26.4	10.6 – 30.6	12.0 – 34.5	13.2 – 37.8
HM30-0900.---	8.3 – 23.5	10.3 – 29.0	12.0 – 33.7	13.5 – 37.9	14.9 – 41.6
HM30-1000.---	9.3 – 26.3	11.5 – 32.5	13.5 – 37.7	15.1 – 42.5	16.7 – 46.6
HM30-1050.---	9.8 – 27.7	12.1 – 34.3	14.2 – 39.8	16.0 – 44.8	17.6 – 49.1
HM30-1100.---	10.3 – 29.1	12.8 – 36.0	14.9 – 41.9	16.7 – 47.1	18.5 – 51.7
HM30-1200.---	11.3 – 31.3	14.0 – 38.7	16.3 – 44.9	18.3 – 50.6	20.2 – 55.4
HM30-1300.---	12.3 – 34.1	15.2 – 42.2	17.7 – 49.0	19.9 – 55.2	22.0 – 60.5
HM30-1400.---	13.2 – 37.0	16.4 – 45.7	19.1 – 53.1	21.5 – 59.8	23.7 – 65.5
HM30-1500.---	14.2 – 39.8	17.6 – 49.2	20.6 – 57.2	23.1 – 64.4	25.5 – 70.5

A wide range of primary air flow rates are possible for each unit length at different primary air pressures and number of STARLINE nozzles specified to suit the particular design. Refer to Dadanco for more detailed selections.

HM30 UNIT WEIGHTS (Table C)

Unit Model	Unit Weight (kg)		
	6 Tube HM30.03-A.262	8 Tube HM30.03-A.282	10 Tube HM30.03-A.102
HM30.03-1500.---	24.9	25.8	41.1
HM30.03-1400.---	23.2	24.0	38.4
HM30.03-1300.---	21.5	22.3	35.6
HM30.03-1200.---	19.0	20.6	32.9
HM30.03-1100.---	17.4	18.9	30.2
HM30.03-1050.---	16.5	18.0	28.4
HM30.03-1000.---	15.7	17.2	27.4
HM30.03- 900.---	14.0	15.5	24.7
HM30.03- 800.---	13.5	13.7	22.0
HM30.03- 700.---	11.6	12.0	19.2

HM30 Supply Air Opening Size

Unit Size	S
HM30.03-A.262	120mm
HM30.03-A.282	120mm
HM30.03-A.102	131mm

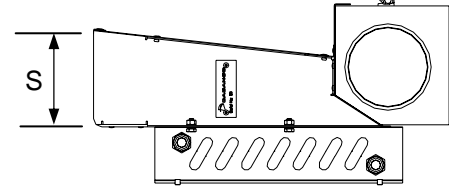

NOTE: Unit weights vary slightly for 1 and 2 row coil and insulated & uninsulated plenum. Refer to Dadanco for specific operating weights for individual unit configurations.

UNIT NOMENCLATURE

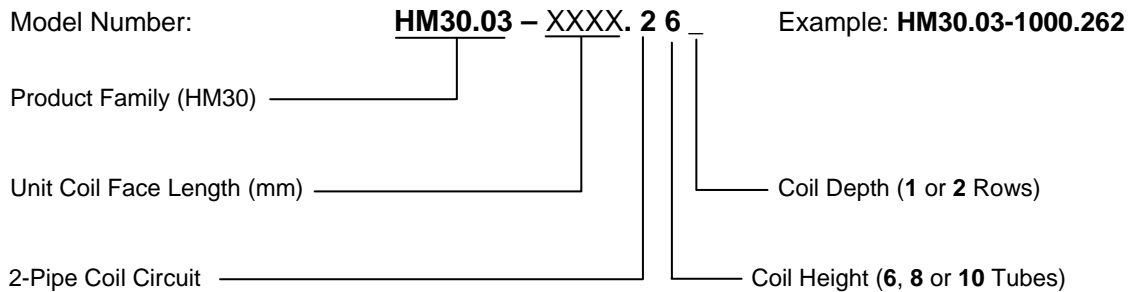

OPTIONS

Available product options (Specify at time of order)

- Left or Right Hand chilled water connections (as viewed looking into the coil face).
- Left or Right Hand primary air spigot connection (as viewed looking into the coil face).
- Rear ovalised Ø150mm equivalent primary air spigot

INSTALLATION

UNITS AS DELIVERED

Each unit is delivered by Dadanco individually packed in a carton containing: -

- The heat exchanger coil secured in place
- The lint screen fitted to the air entry side of the heat exchanger coil
- All nozzles fitted
- A 5mm plugged sampling tube to measure the pressure in the primary air plenum
- 1/2" male BSP flat faced tapered thread connections on the coil inlet and outlet

If insulation is nominated at the time of ordering, the primary air plenum will be insulated with foil faced 6mm cellular insulation material. The insulated plenum will be factory fitted with the primary air spigot, eliminating the flexibility of choosing primary air inlet unit handing at site.

INSTALLER TO PROVIDE

The installer is to provide the following: -

- A mounting system or frame. This should allow the unit to be supported from above and for the air discharge opening to align to the supply air grille neck without any significant gaps.
- Secondary water flow and return piping with isolation valves (both lines) and flow control valves.
- Thermostat control or BMS connections
- Primary air ductwork for delivery of conditioned primary air to each HM30 terminal unit.
- Primary air volume control / balancing device for each primary air flexible duct takeoff.
- Supply air discharge grille
- Return air grille or relief opening in the ceiling bulkhead

INSTALLING THE UNIT

To prepare the STARLINE HM30 induction unit for mounting and connection, carry out the following procedures: -

- Determine the orientation of the air and water connections.
- Ensure there is adequate space within the unit enclosure or bulkhead for the installation of the unit. Check that this space is clear of other services.
- Check the installation space for the unit, to ensure adequate clearance to remove the lint screen during maintenance, and to make piping and duct connections. The space for the lint screen removal will provide adequate air entry space to the heat exchanger coil.
- Ensure the return air path to the unit is clear and does not restrict airflow to the unit.
- Position the unit in the ceiling space or bulkhead with the supply air opening aligned to the penetration for the supply air grille.
- Return air opening should be provided by a return air grille in the bulkhead beneath the HM30 unit or by a 50-75mm relief slot at the perimeter.

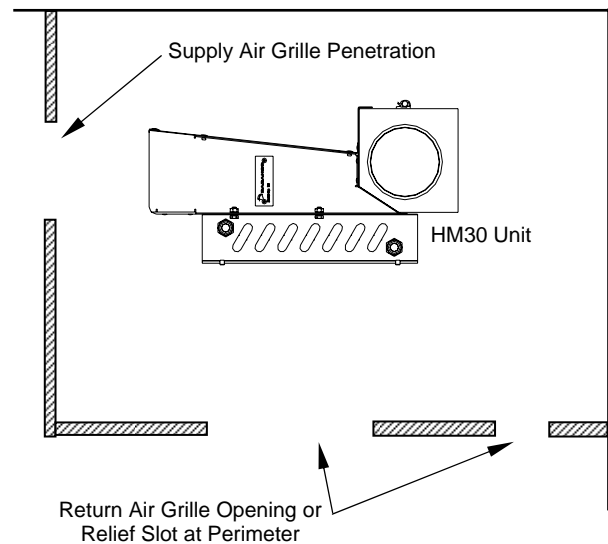

- Secure the HM30 unit in the ceiling space to the supporting frame or slab above with threaded rods or ceiling wire.
- Install the mounting rods or ceiling wires to the 9mm mounting slots provided in the top plate bracket of the HM30 unit mixing chamber.
- Ensure the HM30 unit is installed in a level attitude with proper alignment to the supply air grille penetration.

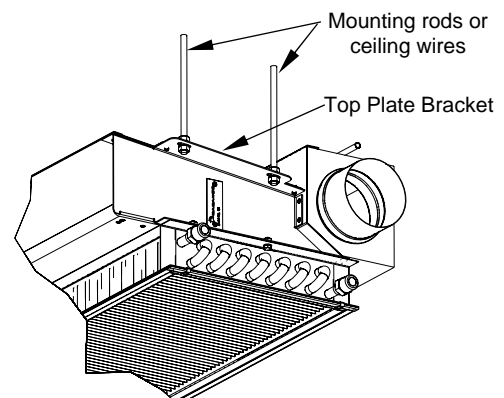

- Connect the primary air flexible duct to the Ø100mm spigot of the primary air plenum.
Primary air inter-connecting flexible duct should be a minimum of 1000mm straight or slightly raiusseed 100mm diameter flexible duct between the primary air duct trunk and the primary air spigot of the HM30 unit.

Where rigid primary air duct is used, flexible connecting duct can be of a shorter length with a straight approach to the unit inlet from the nearest raiusseed bend in the rigid ductwork.

NOTE: Do Not install flexible duct with sharp bends or restrictions upstream of the HM30 unit primary air spigot connection and plenum.

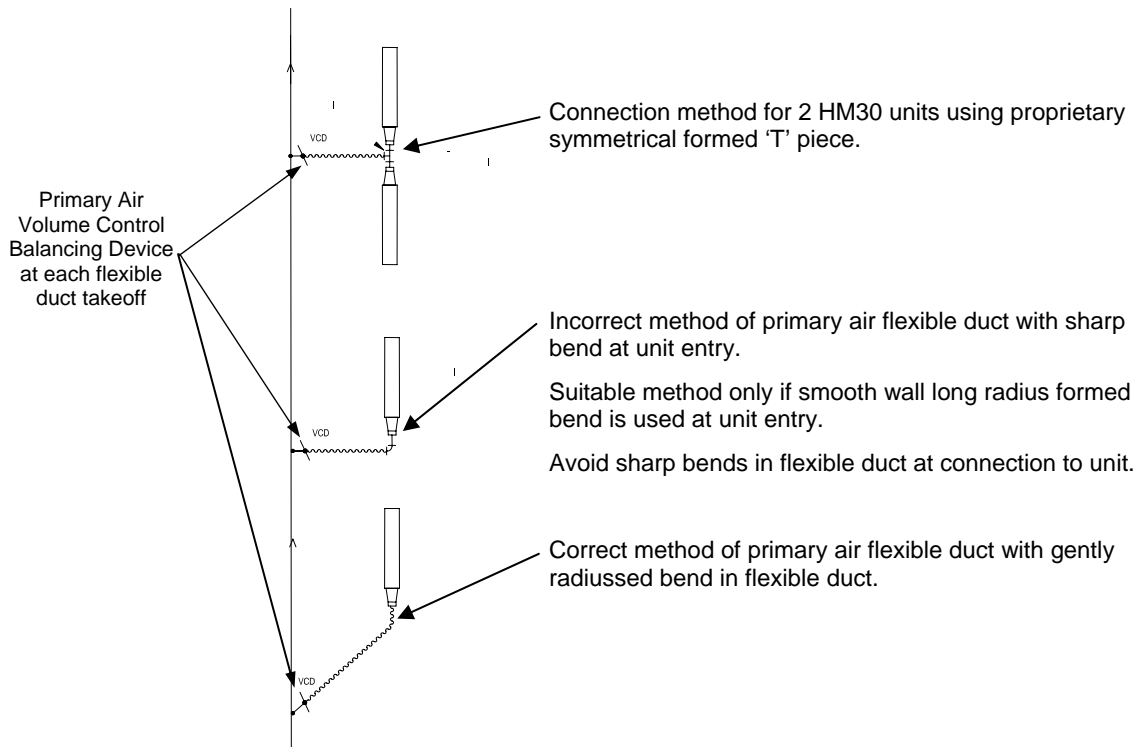

- Make a vapour tight seal with approved tape at the duct insulation and plenum spigot joint.
- Install the chilled water piping and valves as indicated on the working drawings. Connect the unit water inlet / outlets to the water reticulation system.

Secondary Water Connections

Single Unit Connection

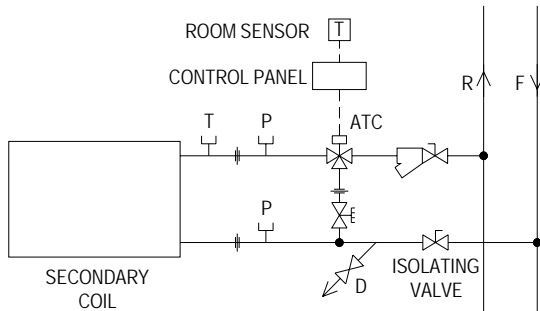

NOTE: It is recommended that the unit be connected with readily removable pipe lengths or flexible hoses to permit disconnection and removal of the coil, should this be required during maintenance.

Dual Unit Connection

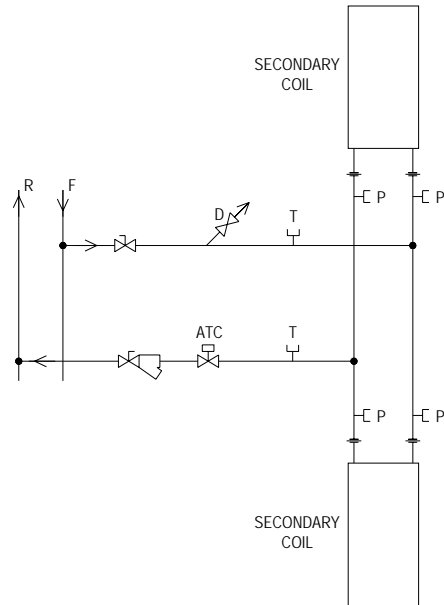

- Ensure that the secondary chilled water piping is aligned with the coil and the coil connection stubs. Use the correct tools to grip the flare nuts and union and apply only sufficient force to make the joint.

Failure to correct any misalignment of the water inlet outlet connections may result in water leaks through cracked water pipe connections. This will void the warranty on the secondary heat exchanger coil.

- Complete the installation by installing the supply air grille and infill piece (if required) to the HM30 unit and bulkhead.

Infill piece between HM30 unit and the supply air grille neck should be site measured for proper fitment and minimal air leakage from the grille neck.

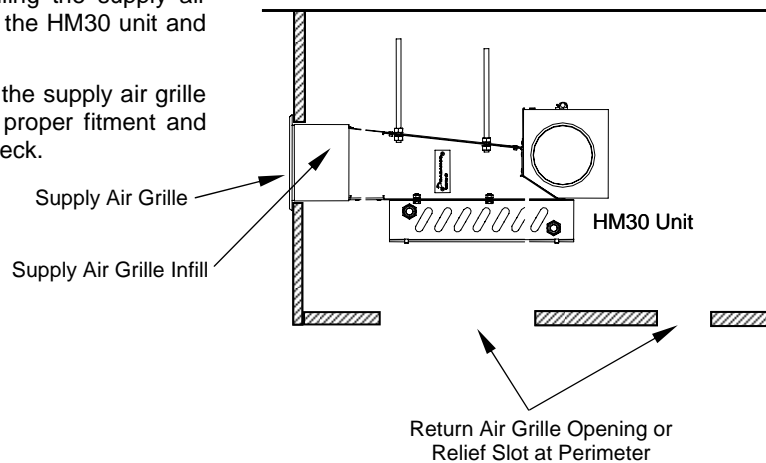

- Install return air grille if required.

COMMISSIONING

The only way to accurately commission the primary air flow to the HM30 Induction Terminal Unit is to measure the static pressure in the plenum. To achieve this, remove the plug from the commissioning point extension tube and insert the Pitot tube instrument into the test point.

NOTE: Do not attempt to measure the static pressure back from the unit at the start of a flexible duct connection. Measure only at the provided commissioning point.

To obtain the designed primary air and total air flow rate, adjust the damper / volume control device as necessary to obtain the specified design primary air plenum pressure to achieve the required primary air flow.

The primary air quantity can be obtained from the pressure/air flow characteristic curve supplied for the unit size.

Replace the rubber plug to seal the test point opening on completion.

NOTES:

Do not attempt to confirm total supply air quantities using a balancing hood measurement method. The airflow from the HM30 unit is a low velocity, low pressure air stream that is well below the accuracy range of restriction imposing measurement hoods. Resistance imposing balancing hoods are not recommended for validating total air quantity.

Do not attempt to confirm the primary air flow quantity by conventional Pitot-traverse methods in the primary air ductwork. Low duct velocities and boundary layer measurement inaccuracies do not permit accurate measurements of duct velocities for primary air installations.

For secondary water flow commissioning, a suitable balancing valve should be installed in order to measure and adjust the secondary water flow to the designed/specified value. Adjust the balancing valve in order to achieve the specified flow rate per unit, according to the unit schedule.

MAINTENANCE

In normal operating conditions the minimum required maintenance involves the heat exchanger coil, the lint screen and the condensate drain tray and consists of:

- Visual inspection to comply with AS3666.2 or local regulations, for grime, lint, bacterial growth, etc., on the heat exchanger coil and in the condensate drain tray. If found, such deposits must be removed immediately, using appropriate methods.
- Yearly mechanical cleaning of heat exchanger coil and lint screen (e.g. vacuuming, brushing).
- Inspect the nozzles for any depositions of dust. Remove and clean nozzles if dirt deposits are found.
- Four yearly chemical cleaning (e.g. washing with health safe chemicals and clean water rinsing).

To remove the lint screen:

- a) Gain access to the underside of the unit through the return air grille or access panel provided by builder.
- b) Pull one corner of lint screen, any corner, downward to free lint screen from secondary coil frame. Lint screen is fitted with a magnetic frame to self-adhere to coil frame.
- c) Move lint screen clear of secondary coil surface and remove through the access opening.
- d) Replace lint screen in the opposite manner by positioning the lint screen aligned to any corner of the secondary heat exchanger and gently pushing the lint screen into place. Magnetic frame of the lint screen will secure the screen to the secondary coil frame.

To remove the heat exchanger coil, ensure the water supply is isolated at the unit, disconnect the water inlet / outlets, remove the lint screen as described above, undo the four fixing bolts on the heat exchanger coil and lift the coil clear.

To replace the coil, reinstall the coil with the four fixing bolts, reconnect the water inlet / outlets and reinstall the lint screen.

STARLINE

HM30 Bulkhead Mounted Induction Units

Guide Specification

Scope

Supply DADANCO horizontal bulkhead mounted induction terminal units type STARLINE HM30-____.____, or equal and approved, fitted with low-noise, high efficiency patented nozzles capable of delivering the primary air quantities as listed in the specification schedule. Connect the units to the primary air duct and secondary water loop in the configuration shown on the drawings.

Construction

The STARLINE HM30 induction terminal unit shall be manufactured to provide a compact unit with a primary air plenum, mounting support points, air entrainment chamber with supply air outlet, secondary heat exchanger and an inlet air lint screen.

Plenum: The medium pressure primary air plenum shall be manufactured of 0.8mm wall thickness galvanised sheet steel designed to incorporate DADANCO multi lobe induction nozzles of the nominated number and size to discharge the specified primary air quantity into the air entrainment chamber.

Nozzles shall be DADANCO multi-lobed induction nozzles of flexible fire retardant polymer, designed for low noise generation and rapid secondary air entrainment.

Provide a circular sheet metal spigot of 100mm equivalent diameter for the primary air flexible duct connection at one end of the unit, or alternatively provide an ovalised sheet metal spigot of 100mm or 150mm equivalent diameter in the centre rear of the primary air plenum.

Insulation (*if required*): Self adhesive, fire retardant foil faced cellular thermal insulation to the exterior of the primary air plenum to prevent condensation forming on the outside of the unit.

The secondary air entrainment chamber shall be constructed of galvanized sheet steel end panels and back plate sealed as an integral part to the primary air plenum. The entrainment chamber will facilitate mounting of the secondary heat exchanger and provide mounting points for installing the unit.

Secondary cooling coil: Fit a removable single two-row (2-Pipe or 4-Pipe) secondary air coil of the specified length required to achieve the specified secondary cooling capacity. Coil shall be constructed of galvanised steel end plates and frames with ½" copper tubes mechanically expanded into 0.145mm thickness rippled edge aluminium fins. Provide ½" BSP male flat face tapered thread fittings on all coil connections.

Secondary coil maximum recommended site test pressure not to exceed 2500 kPa (25 Bar) with continuous maximum recommended operating pressure of 1680 kPa (16.8 Bar). Coil to be factory pressure tested to 2500 kPa and conform to a burst pressure rating of 13,000 kPa (130 Bar) at 50°C.

Coil capacities shall be equal to the specified secondary air sensible cooling capacity when operated at the scheduled secondary chilled water flow and inlet temperature.

Lint screen (*if required*): Fit a serviceable lint screen with frame over the face of the secondary heat exchanger. Fabricate the lint screen from fine plastic fabric mesh, as specified, held in a rectangular aluminium frame. Provide fixing clips to secure the lint screen frame to the secondary coil.

The unit shall be mounted by its support brackets to a suitable frame or support structure in a manner to ensure leak free connection to the supply air discharge vents and unrestricted secondary air entry to the unit.

DISCLAIMER: While every effort is made to ensure the details contained herein are kept up to date, in the interest of ongoing product development DADANCO reserves the right to alter the information without notice.